

A CONFORMAL ARRAY EXAMPLE

A conformal antenna is an antenna that conforms to a prescribed shape which is not necessarily optimized for antenna performance. The purpose is to build the antenna so that it becomes integrated part with the structure. The shape of the surface can be singly curved as the fuselage or wings of an airplane or doubly curved as the nose.

The circular cylindrical C-band array was formed by rectangular waveguide apertures on a cylinder surface. The diameter of the cylinder was 600 mm and it has 54 azimuthally polarized waveguide aperture elements with 0.7λ spacing at 5.65 GHz in the E-plane. There are three rows with 18 elements each, extending over about 120° in the azimuth.

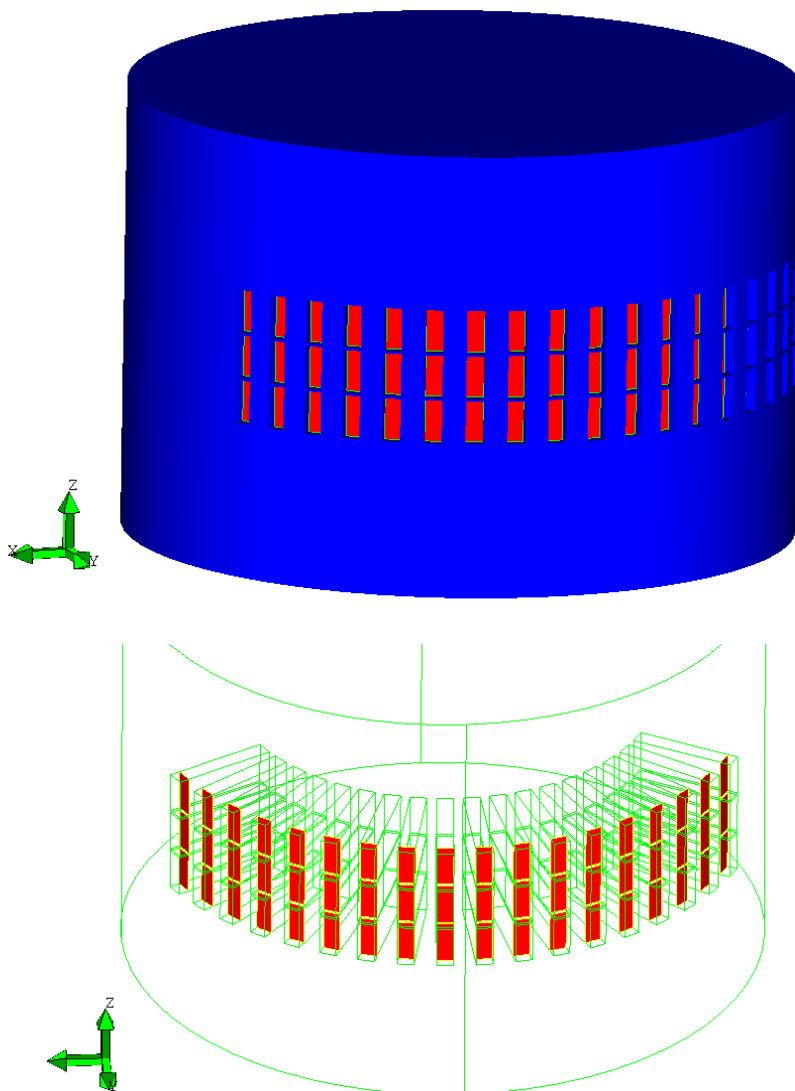

Figure 1. The cylindrical C-band array with three rows of 18 elements each, extending over about 120° in the azimuth.

Lattice:

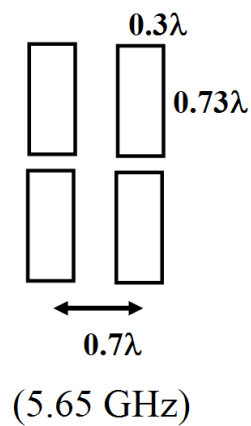

Figure 2. Array parameters.

The radiating elements on the cylinder are forming a circular array. Far-field patterns were generated for different scanning angles by assuming constant amplitudes.

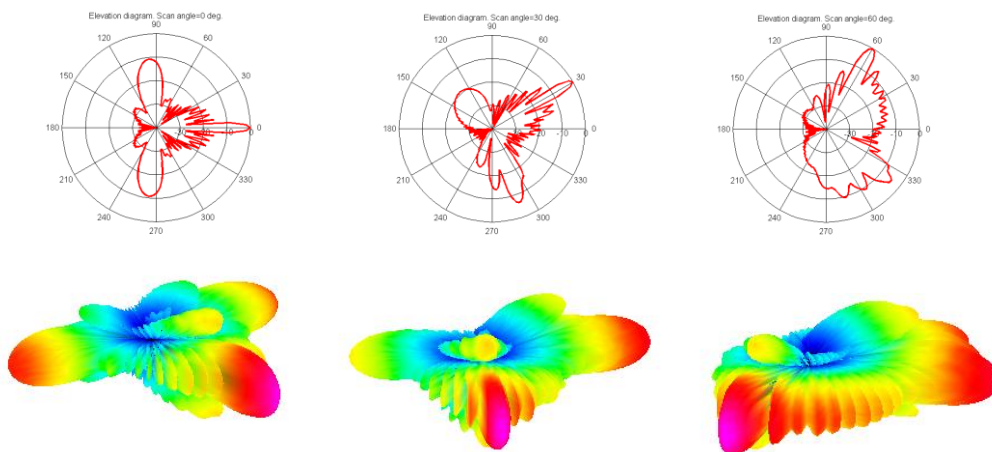

Figure 3. Far field patterns for scan angle $\phi=0^\circ$, $\phi=30^\circ$ and $\phi=60^\circ$ using constant amplitude.

Data for the circular cylindrical C-band array:

- Element grid Rectangular, 3×18 elements extending over about 120°
- Element spacings 37.1 mm in the azimuth
- 41 mm in the axial direction
- Cylinder radius: 300 mm
- Cylinder height: 400 mm
- Frequency interval 4.3 6.8 GHz
- Frequency used here $f = 5.65$ GHz

Simulation data	
Total number of nodes	41 000
Total number of triangles	82 000
Total number of MM unknowns	123 000
Time (excluding post processing)	2.5 h ¹

1/Two processors on an AMD Dual Core Opteron 285 2.6 GHz with 16 GB memory

Efield AB, Skalholtsgatan 10 B,
SE-164 40 Kista, Sweden
Tel: +46 8 410 03 510
Email: contact@efieldsolutions.com
www.efieldsolutions.com